

# BMP62 | Brushless

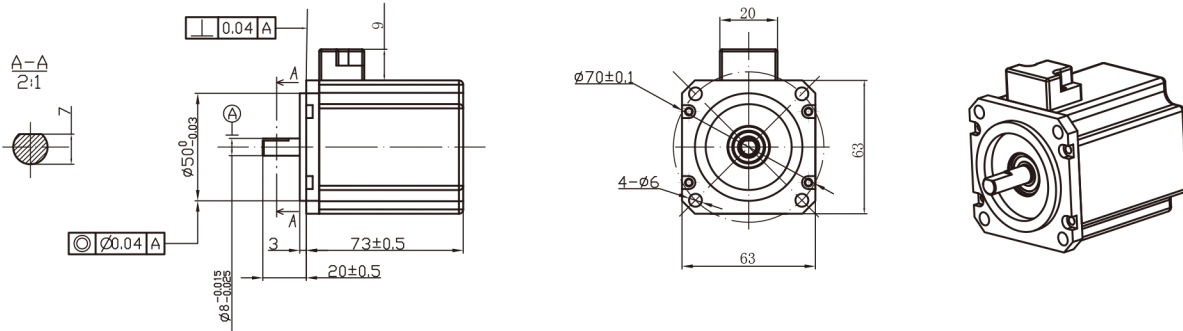

## Motor Data

电机型号	Motor model		BMP6212	BMP6224	BMP6236		
1	额定电压	Nominal voltage	VT	12	24	36	VDC
2	空载转速	No load speed	Wnl	4000	4000	6000	rpm
3	空载电流	No load current	InI	<2	<1	<1	A
4	额定转速	Nominal speed	Wc	3000	3000	4520	rpm
5	额定转矩	Nominal torque	Tc	0.6	0.6	0.6	Nm
6	最大转矩	Maximum torque	TP	1.2	3.6	3.6	Nm
7	额定电流	Nominal current	Ic	22.8	11.4	11.4	A
8	最大电流	Maximum current	IP	45	68.4	68.4	A
9	额定功率	Nominal power	PR	188	188	284	watts
10	最大功率	Maximum power	Pmax	363	363	729	watts
11	线间电阻	Terminal resistance	Rt	0.08	0.31	0.31	Ω
12	线圈电感	Terminal inductance	L	9	35	35	μH
13	转矩常数	Torque constant	Kt	0.029	0.058	0.058	Nm /A
14	齿槽效应	Cogging	Tc Th	0	0	0	mNm
15	转子惯量	Rotor inertia	J		1.98		Kg*cm^2
16	最高绕组温度	Max. winding temperature	Temp		120		°C
17	极对数	Number of pole pairs	p		4		
18	重量	Weight	Wt		0.83		kg
19	电机绝缘等级	Motor insulation class			class B		
20	防护等级	Protection class			IP64		
21	使用环境	Ambient temperature			-20~+40°C		
22	接线定义	Terminal definitions	U: 绿 V; 黑 W; 红 +5V; 黄 GND; 灰 H1; 棕 H2; 橙 H3; 蓝 温控电阻; 紫				

## Graph

Torque - Speed - Current

