

Motor Data

电机型号	Motor model			DR132203B	DR132205B	DR132206B	DR132209B	DR132212B	DR132215B
1 额定电压	Nominal voltage	V	V	3	5	6	9	12	15
2 空载转速	No load speed	rpm	Wnl	12500	13000	12700	12500	13000	13200
3 空载电流	No load current	mA	InI	92	48	48	36	28	22
4 额定转速	Nominal speed	rpm	Wc	8400	9970	7400	8300	8460	7960
5 额定转矩	Nominal torque	mNm	Tc	1.32	1	1.31	1.29	1.27	1.28
6 额定电流	Nominal current	A	Ic	0.61	0.28	0.31	0.2	0.16	0.13
7 输出功率	Output power	W	Pc	1.16	1.06	1.02	1.13	0.94	1.07
8 堵转扭矩	Stall torque	mNm	Tmax	3.61	3.9	3	3.44	3.21	3.4
9 堵转电流	Stall current	A	Imax	1.67	1.1	0.7	0.54	0.39	0.35
10 最大效率	Max. efficiency	%	ηmax	69	69	53	70	69	69
11 线间电阻	Terminal resistance	Ω	Rt	1.8	4.5	8.8	16.8	30.6	42.7
12 力矩系数	Torque constant	mNm / A	Kt	2.16	3.51	4.2	6.4	8.18	9.65
13 速度常数	Speed constant	rpm / V	Kn	4410	2717	2295	1488	1167	990
14 速度扭矩比	Speed torque gradient	rpm / mNm	Δn / ΔT	3112	2893	4113	3200	3574	4645
15 线间电感	Terminal inductance	mH	L	0.039	0.102	0.152	0.355	0.63	0.878
16 转子转动惯量	Rotor inertia	gcm ²	J	0.3	0.32	0.32	0.32	0.31	0.32

Specifications

- 1 ambient temperature Ta -20~+65°C
- 2 Max.winding temperature Tcoilmax +85°C
- 3 Max.speed Nmax 16000rpm
- 4 axial play Δt 0.05~0.15mm
- 5 number of pole pairs p 1
- 6 number of commutator segments 5
- 7 weight of motor Wt 16g
- 8 Max.axial load(dynamic) 0.8N
- 9 Max.force for press fits(static) 15N
- 10 Max.radial load,4mm from flange 1.4N

Operating Range

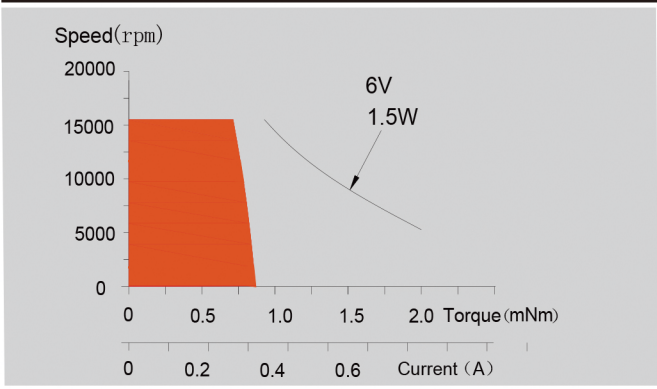

SMJ Modular System

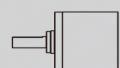

Planetary Gearhead
Type P12H
Diameter φ12
Torque 0.004~0.2N·m
See page 35



Magnet Encoder
1000 CPT
3 channels
see page 32